

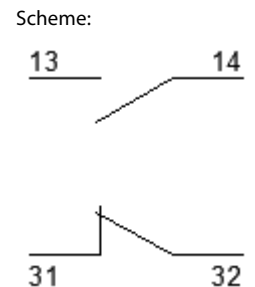

MECHANICAL DEVICE WITH LIMIT SWITCH

AEX/DMBxxC

Reference	Thread	Nominal pressure
AEX/DMB12C	G 1/2"	500 Bar
AEX/DMB34C	G 3/4"	400 Bar
AEX/DMB1C	G 1"	350 Bar
AEX/DMB114C	G 1 1/4"	350 Bar
AEX/DMB112C	G 1 1/2"	350 Bar

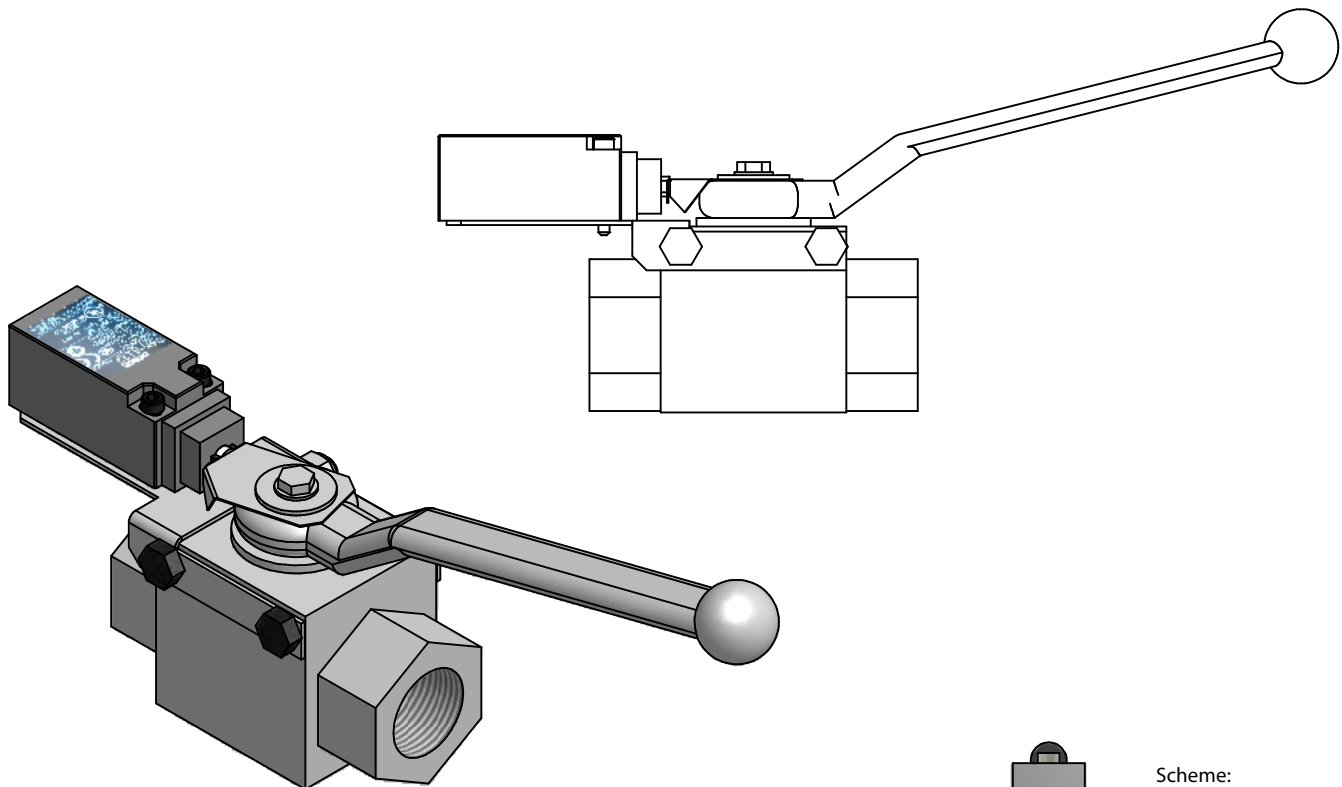

Specifications	
Name	Value
Material Valve	Carbon steel
Type of valve	2 ways
AC-15	3A/240VAC
DC-13	0.27A/250VDC
Degree of protection	IP 65
Feed-through wiring	M16x1.5
Purpose limitation	Interiors



Av. Alfonso Peña Boeuf, 6 y 9
28022 MADRID - ESPAÑA
TEL: +34 913121656
FAX: +34 913295820

DATA SHEET MECHANICAL DEVICE WITH LIMIT SWITCH

Description: Device used to manually block the discharge of extinguishing agent. It has a position indicator with the valve completely open.

Code sheet:	Group sheet:	Reference:	Drawn:	Date:	Revised:	Date:	Review:	Format:
AEX-FTC-02-001	CO2	VER TABLA	DCM	25/09/2015	MRC	25/09/2015	1	A4